

Hydracrop 80

Where production requires twin operator machines, higher speeds or greater capacity, **GEKA** provides the solution with the **HYDRACROP** range with five working stations: punching, notching, shearing of flat bars, angles and \emptyset and \square bars.

HYDRACROP 80	
SHEAR FOR FLAT BARS	
Shearing capacity	18"x5/8" / 12"x3/4"
Working height	33 1/2"
SHEAR FOR SECTION IRON	
Shearing capacity	150 Ton
L at 90 °	5"x5"x1/2"
L at 45°	3"x3"x5/16"
SHEAR FOR BARS	
Round bar \emptyset	13/4"
Square bar \square	13/4"
WITH SPECIAL BLADES	
UPN Profiles	5"
IPN Profiles	5"
NOTCHING	
Plate thickness	15/32"
Depth	31/2"
Width	2"
PUNCHING	
Punching power	88 Ton
Maximum capacity with quick change and die with gooseneck die holder	\emptyset 11/2"x 9/16" \emptyset 7/8"x7/8"



Punching station

The punching station is fitted with an independent cylinder that creates a large, flexible, universal workstation easily adaptable for mounting special tools and "die sets".



Cylinder support



Split double acting cylinder



Limit switches for punch travel setting



Generous travel for bending, deep-drawing, forming jobs etc



Adjustable generous non-turning guiding



Additional guiding for damping of offset forces and protection of hydraulic seals



Spindle for fitting of special tools



Quick punch change



Adjustable material stripper



Table with millimetre scales, included in production package



Adjustable measuring stop up to 500 mm



Gooseneck die-holder for punching channel and section



Adjustable bolster locking device X axis



Adjustable bolster locking device Y axis



Fixing bolt at base of gooseneck

L cutting angle

Fully aware of the importance of distortion free shearing, GEKA has designed a patented system of a floating upper blade that travels along a rectilinear line and is able to shear angles without any deformation and loss of material (single cut); All GEKA Hydracrop models ensure that distortion problems caused by the conventional radial system are now a problem of the past.



Adjustable Support



Blade gap adjustment screws



Upper shear blade without deformation



Upper shear blade guides



Safety protection

Shearing for flat bars

The excellent stability of the monoblock blade-holder, which is controlled at the each end, makes it possible to mount a long upper blade with a proven geometry to obtain optimum shearing quality. The radial system allows a generous cutting capacity as a result of the force multiplier effect.

1. Lower blade
2. Upper blade with special geometry
3. Clearance control between shear blades
4. Supplement shearing angle control of upper blade, for shearing without deformation.
5. Adjustable guides 45° right and left.
6. Flat plate/bar shearing table.
7. Slotted guide positioning with coverage of the entire blade length
8. Guide fixing screw
9. Clearance control of blade-holder

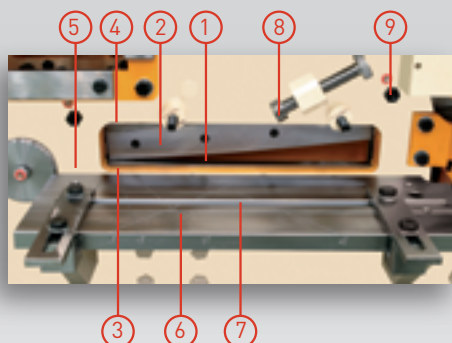

Hydracrop 80

Notching station

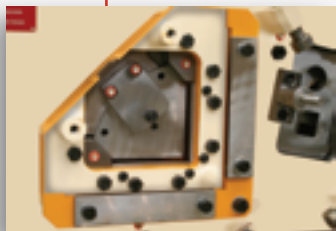

This station of the machine has been designed to mount several optional accessories, all of which are normally held in stock.

- Triangular notching at 90°
- Tube notching equipment
- Notching of footings

Rectangular punch

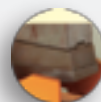

Material stripper



Cross centring bolts



Fixing holes special tooling



Rectangular notching



Table with scaled measuring stops, included in production kit



Cutting of \emptyset and ∇ bars

The GEKA HYDRACROP machines are fitted as standard with blades for cutting \emptyset and ∇ bars. Furthermore, this station has been designed bearing in mind the shearing of other sections such as L, I, Z for which a large stock of blades is available.

Adjusting bolt and height setting of the guide



Blade holding flanges



Guide fixing bolts

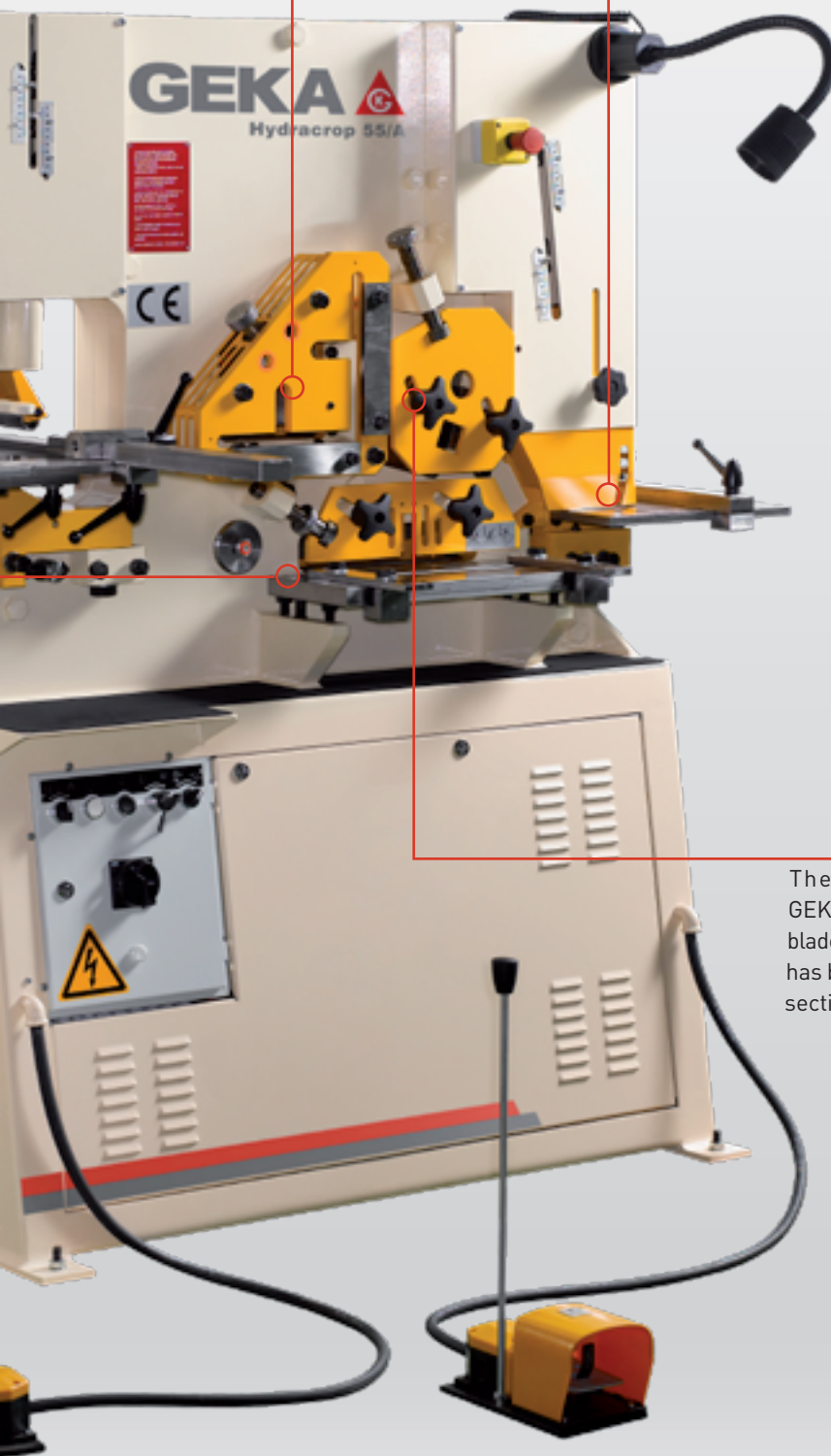

- 
- World leader in punching and shearing solutions
 - Worldwide distribution network
 - Proven quality, design and craftsmanship
 - Continuous innovation
 - Complete after sales service
 - Great versatility that includes the highest range in accessories and optional equipments in the market
 - The only machine fully produced and manufactured in the European Union
 - All GEKA machines are special order. GEKA is the only ironworker that you can customize to fit your needs

www.geka.es

Distribuidor: